

HYTEL
CID-8 8-LINE CALLER ID INTERFACE UNIT
USER'S MANUAL

Hytel

Distributed in Australia by
Access Communications Pty Ltd
33 Alleyne Street
Chatswood NSW 2067
Tel: (02) 9417 5311
Fax: (02) 9417 6976
Email: hytel@accesscomms.com.au

Table of Contents

SECTION 1. OVERVIEW 3

 1.1 FUNCTIONAL DESCRIPTION 3

 1.2 OUTPUT MESSAGE FORMAT 5

 1.3 SPECIFICATIONS 6

SECTION 2. CID-8 INSTALLATION ON A HYTEL SYSTEM 7

 2.1 PROGRAMMING THE HYTEL SYSTEM FOR CID-8 OPERATION 7

 2.2 SETTING THE PORT FOR ICLID OPERATION 8

 2.3 SETTING JUMPERS ON THE CID-8(S) 9

 2.4 MOUNT THE CID-8(S) 9

 2.5 CONNECT CID-8(S) TO THE HYTEL 9

 2.6 CONNECT EXCHANGE LINES TO THE CID-8 12

 2.7 CONNECT POWER TO THE CID-8(S) 13

SECTION 1. OVERVIEW

1.1 Functional Description

- 1.1.1 The Hytel CID-8 Caller ID interface unit receives the calling identification information delivered by the Telephone Carrier and sends the information in ASCII format to a computer, terminal, printer or other DTE (Data Terminal Equipment) device through RS-232C asynchronous serial communication.
- 1.1.2 The CID-8 is compatible with the Hytel HYD-824, HYD-96 and HYD-120 Digital Key Telephone Systems.
- 1.1.3 Each CID-8 can support 8 telephone lines. Up to 12 CID-8's can be connected together (actual number is limited by KSU specifications) to support up to 96 exchange lines.
- 1.1.4 There are two DB-9 connectors, labelled "IN" and "OUT" as shown in Fig.1. These connectors are used for RS-232C asynchronous serial communication and can enable up to 12 CID-8's to be connected together.
- 1.1.5 There are three 6-position RJ12C connectors, named with "1-3", "4-6" and "7-8" located in the CID-8 as shown in Fig.1. These are used to directly connect to incoming telephone lines. The first 2 ports provide 3 telephone line connections and the last one provides 2 telephone line connections.
- 1.1.6 There is a 3-position jumper named JP1 in the CID-8 as shown in Fig.1 for selecting the baud rate of RS-232C asynchronous serial communication. The baud rate is selectable between 9600, 4800 and 2400. The other serial parameters are set at 1 start bit, 8 data bits, 1 stop bit and no parity bit and cannot be changed.
- 1.1.7 The power connector, labelled "DC-IN" as shown in Fig.1 provides DC power input connection. CID-8 can be connected directly to the 24V power output terminals of the Hytel KSU with the cord supplied or an optional Power Adaptor is available to connect to a 240V AC mains outlet. The accepted range of DC power input is from 12V DC to 35V DC and polarity is not important.
- 1.1.8 Items supplied:
- CID-8 Interface Unit
 - DB9 to DB9 RS-232C cable
 - DC power cable
 - CID-8 Manual (this book)

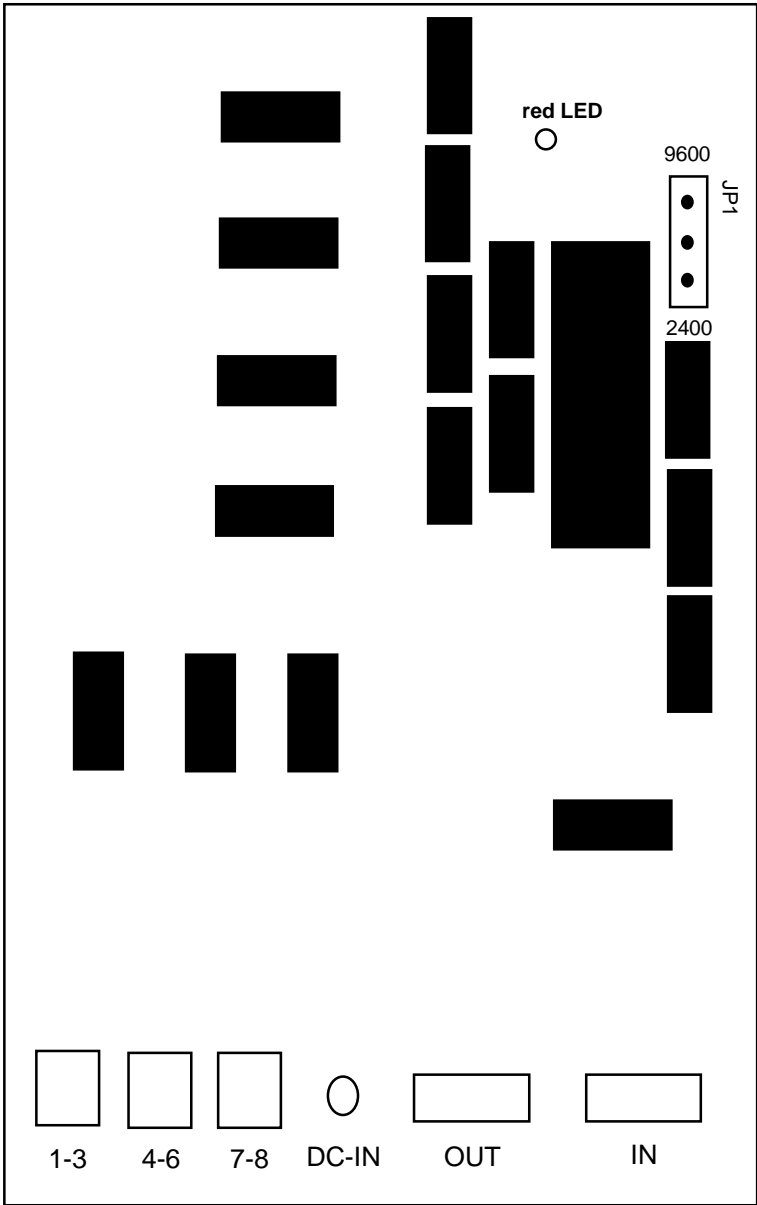

Fig. 1 CID-8 PCB layout diagram

1.2 Output Message Format

1.2.1 RS-232C Output Message Format

Upon receiving the standard calling identification information from the exchange lines, the CID-8 "stamps" the information with the line number and converts the information to ASCII format messages as listed as following table. The line number is the only part of output message that is CID-8 supplied. See section 2.6 which shows what line number the CID-8 "stamps" for each incoming telephone line.

Characters	Description	Example
1 ~ 2	Line number	'04','25'
3 ~ 7	Spaces	' '
8 ~ 12	Date	' 1/07','10/10'
13 ~ 17	Spaces	' '
18 ~ 25	Time	'12:56 PM',' 7:35 AM'
26 ~ 30	Spaces	' '
31 ~ 44	Phone number	' 12058814000','12345678901234'
45 ~ 49	Spaces	' '
50 ~ 50	Long Distance Indicator	' ','L'
51 ~ 55	Spaces	' '
56 ~ 70	Name	' Bill Becker'
71 ~ 72	CR and LF	CR,LF

1.2.2 Example of RS-232C Output Message

Line Number	Date	Time	Phone Number	* Name
01	7/15	12:20 AM	0294175311	TOM JONES
05	7/15	6:30 AM	1234567	JOHN MORSE
07	7/16	10:05 AM	PRIVATE	
12	7/16	12:57 PM	OUT OF AREA	
99	12/31	1:30 PM	0412123456	BILL GORDON

*Note: Calling Name" information is not currently provided by Australian telecommunications carriers (March '99).

1.3 Specifications

- (1) Electronic:
- | | |
|----------------------|------------------|
| Power Supply Voltage | 12V DC to 35V DC |
| Power Supply Current | 100mA @ 12V |
| Receive Level | -10 to -33 dbm |
- (2) RS-232C asynchronous serial communication:
- | | |
|-------------------------|------------------|
| Baud Rate | 2400, 4800, 9600 |
| Start Bit | 1 |
| Data Bits per Character | 8 |
| Parity | None |
| Stop Bit | 1 |
- (3) Environmental:
- | | |
|-----------------------|---------------|
| Storage Temperature | -18°C to 65°C |
| Operating Temperature | -12°C to 49°C |
| Relative Humidity | 5% to 95% |
- (4) Mechanical:
- | | |
|--------|---------|
| Height | 63.1 mm |
| Width | 186 mm |
| Length | 322 mm |
| Weight | 0.8 Kg |
- (5) Power Adaptor (Optional)
- | | |
|-------------------|--------------|
| AC Voltage Input | 240V AC |
| DC Voltage Output | 12V DC |
| Power requirement | 100mA at 12V |

SECTION 2. CID-8 INSTALLATION ON A HYTEL SYSTEM

2.1 Programming the Hytel System for CID-8 operation

Main Menu	Call Handling	
Sub Menu	Category 3	
Item	ICLID Delay Ring Time	
	New Data	3

Delay time can be increased to allow handling of simultaneous calls.

Main Menu	Call Handling	
Sub Menu	Category 4	
Item	SMDR for ICLID Name	
	New Data	N
	Enable ICLID SMDR	
	New Data	(N/Y)

Enable ICLID SMDR

If set to "Y" the system generates an SMDR record when an ICLID call is answered by a voice-mail port.

Main Menu	Resource	
Sub Menu	RS232 Baud Rates	
Item	RMT Baud Rate	
	New Data	2400

Main Menu	CO Line Application	
Sub Menu	ICLID	
Item	Line #	
	New Data	See Note

Note: For each directory number, specify which port of the CID-8(s) is to be used for that particular directory number. A Hytel 96/120 system only allows up to 9 CIDs (72 lines) to be connected.

2.3 Setting jumpers on the CID-8(s).

- 2.3.1 The data speed must be set to 2400. A 3-position jumper, JP2, located in the CID-8 as shown in Fig.1 is used to select the baud rate of RS-232C asynchronous serial communication. JP2 is set for a baud rate 2400 bps as shown:

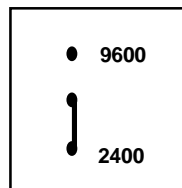

3-position jumper, JP2

2.4 Mount the CID-8(s).

- 2.4.1 Mount the CID-8(s) in a convenient location near the KSU and prepare to run the interconnecting cabling.

2.5 Connect CID-8(s) to the Hytel.

- 2.5.1 The “out” connector of the first unit is used to connect the CID-8 to the Hytel KSU, a computer, a terminal, a printer or another DTE device.
- 2.5.2 The “in” connector of the first unit is only used if there are multiple units installed. A DB9 cable is taken from this “in” connector to the “out” connector of the second CID-8.
- 2.5.3 In Fig.2, there are 3 CID-8's connected together to provide 24 lines service. Up to 12 CID-8's can be connected together to share a DTE device. The DTE device is always connected to first CID-8. The corresponding line numbers in the output message as shown in section 1.2 for each CID-8 are listed as follows.

Line numbers “01” ~ “08” correspond to lines 1~8 of 1-st CID-8
Line numbers “09” ~ “16” correspond to lines 1~8 of 2-nd CID-8
Line numbers “17” ~ “24” correspond to lines 1~8 of 3-rd CID-8

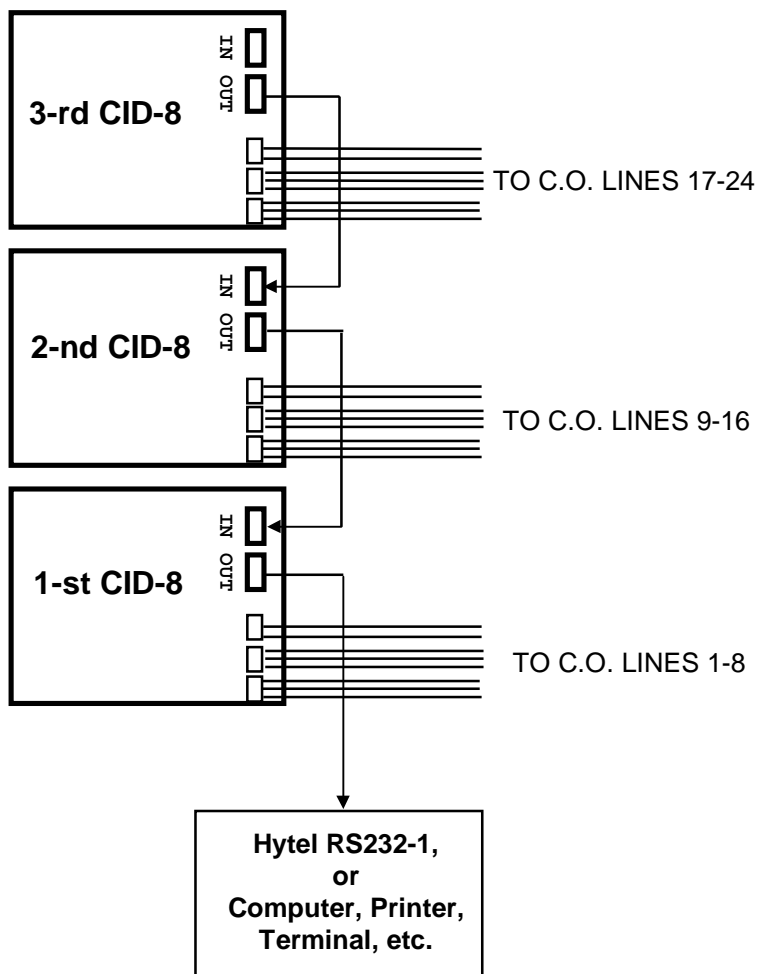

Fig 2. Example of multiple CID-8 connections.

2.5.4 RS-232C Output Connector

This is a male DB9 connector, labelled with "OUT" in CID-8 as shown in Fig.1. In single CID-8 configuration, it is connected to the KSU or another DTE device for message output. In multiple CID-8 configuration, it is connected to RS-232C input of previous CID-8 for non-first CID-8 as shown in Fig.2. The pin definitions of this connector are listed as following table.

Pin Number	Definition
1	Not Connected
2	Not Connected
3	Serial Data Output
4	Internally connected to pin 6
5	Ground
6	DSR (Data Set Ready) Input
7	Internally connected to pin 8
8	Internally connected to pin 7
9	Not Connected

2.5.5 RS-232C Input Connector

This is a female DB9 connector, labelled with "IN" in CID-8 as shown in Fig.1. and in a single CID-8 configuration, is not used. In multiple CID-8 configuration, it is connected to RS-232C output of next CID-8 for non-last CID-8 as shown in Fig.2. The pin definitions of this connector are listed as following table.

Pin Number	Definition
1	Not Connected
2	Not Connected
3	Serial Data Input
4	Not Connected
5	Ground
6	DTR (Data Terminal Ready) Output
7	Not Connected
8	Not Connected
9	Not Connected

2.6 Connect Exchange Lines to CID-8.

2.6.1 Connect incoming C.O. (Exchange) Lines to the RJ12C connector(s).

The CID-8 is a parallel connection across the exchange lines and this can be achieved;

On a Hytel HYD-824 system:

By using a 6P6C modular double adapter plugged into the exchange line RJ12C socket on the Krone connect module in the KSU.

On a HYD-96/120 system:

By "double-connecting" at the distribution frame.

2.6.2 The maximum line numbers connected and the corresponding C.O. lines are listed in the following table for each RJ-12C connector.

Connector Name	Maximum Line Number	Corresponding C.O. lines
"1-3" RJ12C	3	1st line to 3rd line
"4-6" RJ12C	3	4th line to 6th line
"7-8" RJ12C	2	7th line to 8th line

2.6.3 Pin definition of RJ-12C connector

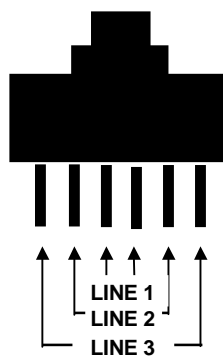

IMPORTANT.

If "flat" cable is used to connect the CID-8 unit to the exchange lines, it is essential to connect all unused wires in the cable together to prevent abnormal system operation.

2.7 Connect Power to the CID-8(s).

- 2.7.1 Plug a suitable power adaptor with a 2.5mm output plug into a 240V AC mains outlet and connect the output plug to the "DC-IN" socket in the CID-8 (polarity is not important).
- 2.7.2. When power is applied, the red LED in the CID-8 (as shown in Fig. 1) will flash to indicate that the system is working.

Do not use the system 24V terminals to power this unit. Those terminals are to be used ONLY for Battery Backup and must not be used to power any auxiliary equipment.